

- 外壳由强化塑胶与锌合金组成，结构坚固，容易配线；
- 体积小，可防水、防油；
- 采用双回路形式，内置双簧片微动开关；
- 配备各种形式的驱动连杆，选型方便；
- 广泛应用于各种机械设备、自动化设备、仪器仪表等领域。
- Strong structure, made of zinc metal alloy and plastics, easy to contact line;
- Small size, oil and water resistant ;
- Double way switch, double spring inner switch;
- Variety of levers;
- Widely used in Mechanical equipment ,automatic machine, and instrument, electro motion tool etc.

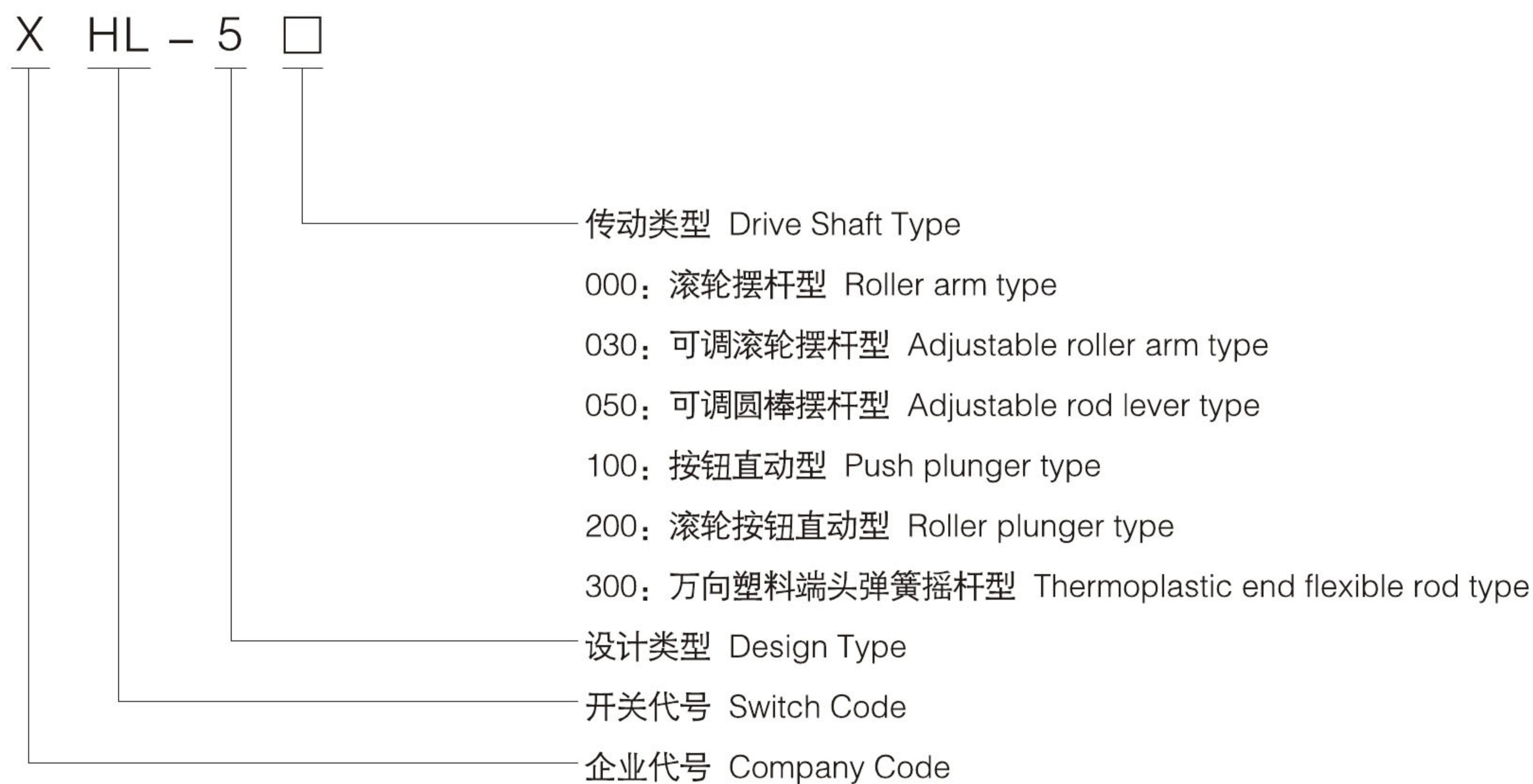

□ 型号含义 Model & Meanings



□ 触点形式、安装孔尺寸、结构图 Contact Forms&Mounting Hole Dimensions&Product Structure

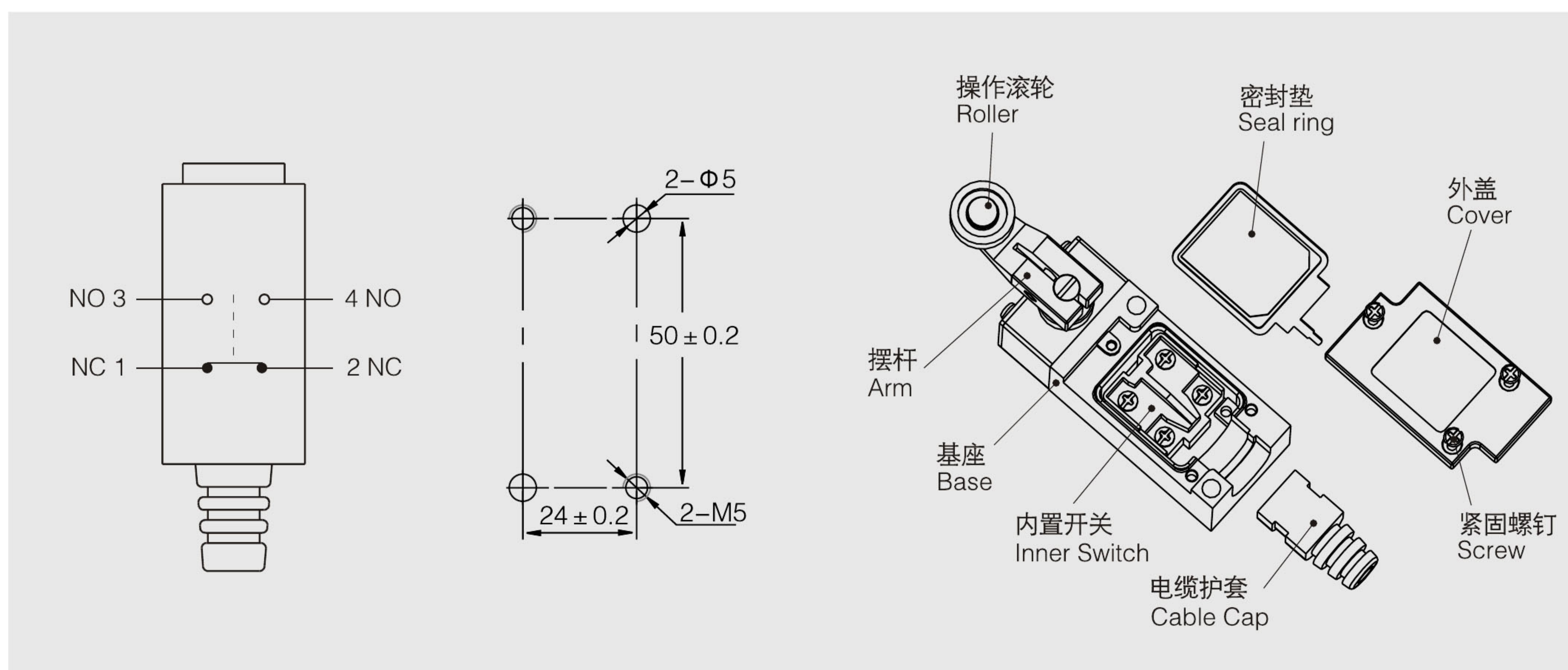

□ 性能参数 Specification

项 目 Item	参数值 Data	
额定负荷 Rating load	5A/250VAC	
操作速度 Operation speed	5mm-50cm/s	
操作频率 Operation frequency	机 械 Mechanical	120次/分 120times/min
	电 气 Electrical	30次/分 30times/min
绝缘电阻 Insulation resistance	100mΩ 以上(Above) DC500V	
接触电阻 Contact resistance	25mΩ 初值 initial value)	
介质耐压 Withstand voltage	非 连 线 Non-connection wire	1000VAC
	各端子间 Every terminal	1500VAC
振 动 Vibration	误 动 作 Misoperation	10-55Hz 复振幅 Amplitude 1.5mm
冲 击 Impact	耐 久 Durable	1000m/s ²
	误 动 作 Misoperation	300m/s ²
寿 命 Life	电 气 Electrical	100,000次以上 above
	机 械 Mechanical	1,000,000次以上 above
防护等级 Protection degree	IP65	
使用温度 Operating temperature	-20~+60°C	
使用湿度 Operating humidity	<85%	

□外形尺寸/动作特性 Dimensions / Operating Characteristics

• 滚轮摆杆型
XHL-5000

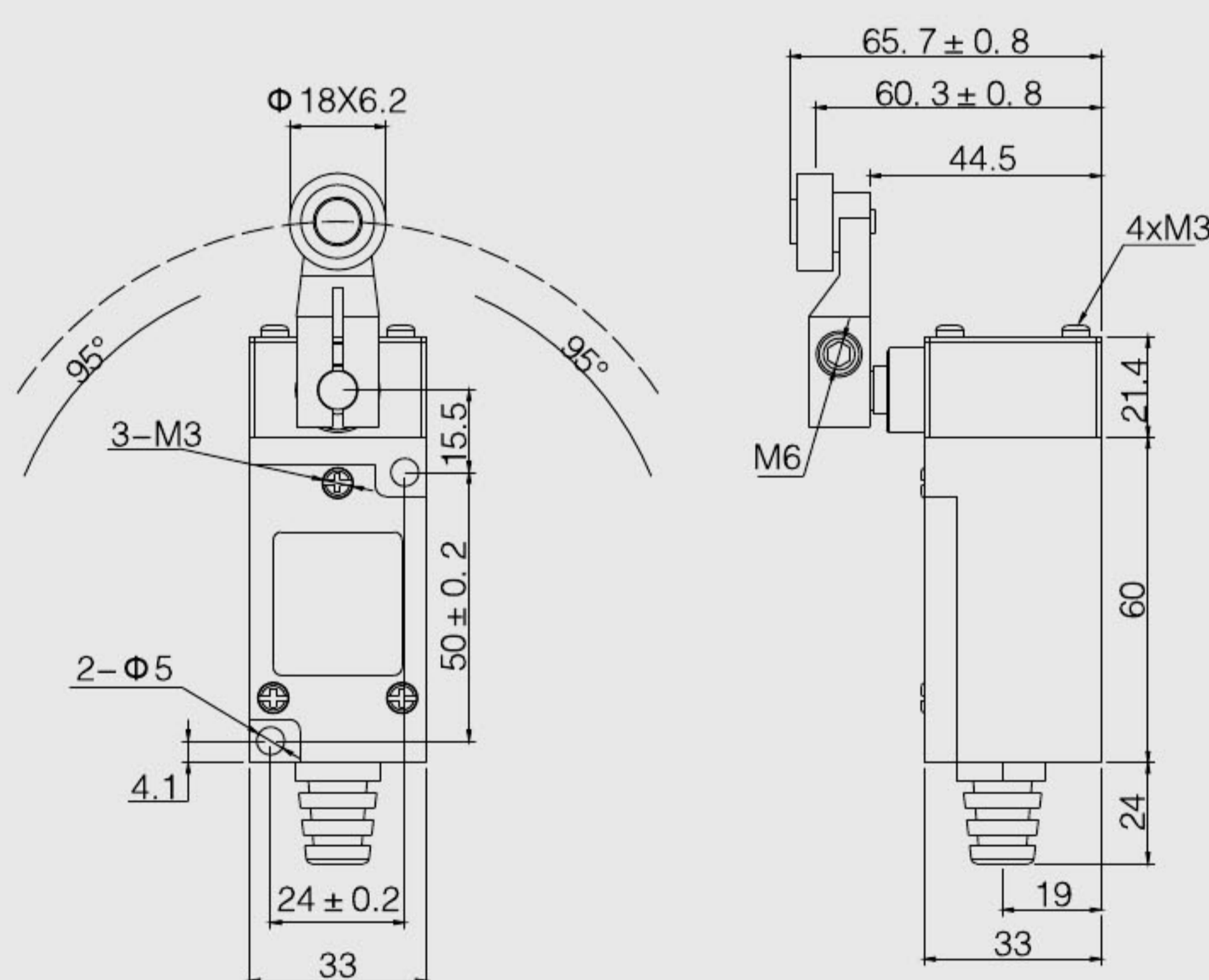

动作力	OF max.	500g(4.9N)
回复力	RF min.	80g(0.78N)
预行程	PT max.	30°
超行程	OT min.	70°
差行程	MD max.	15°
总行程	TT	90

• 可调滚轮摆杆型
XHL-5030

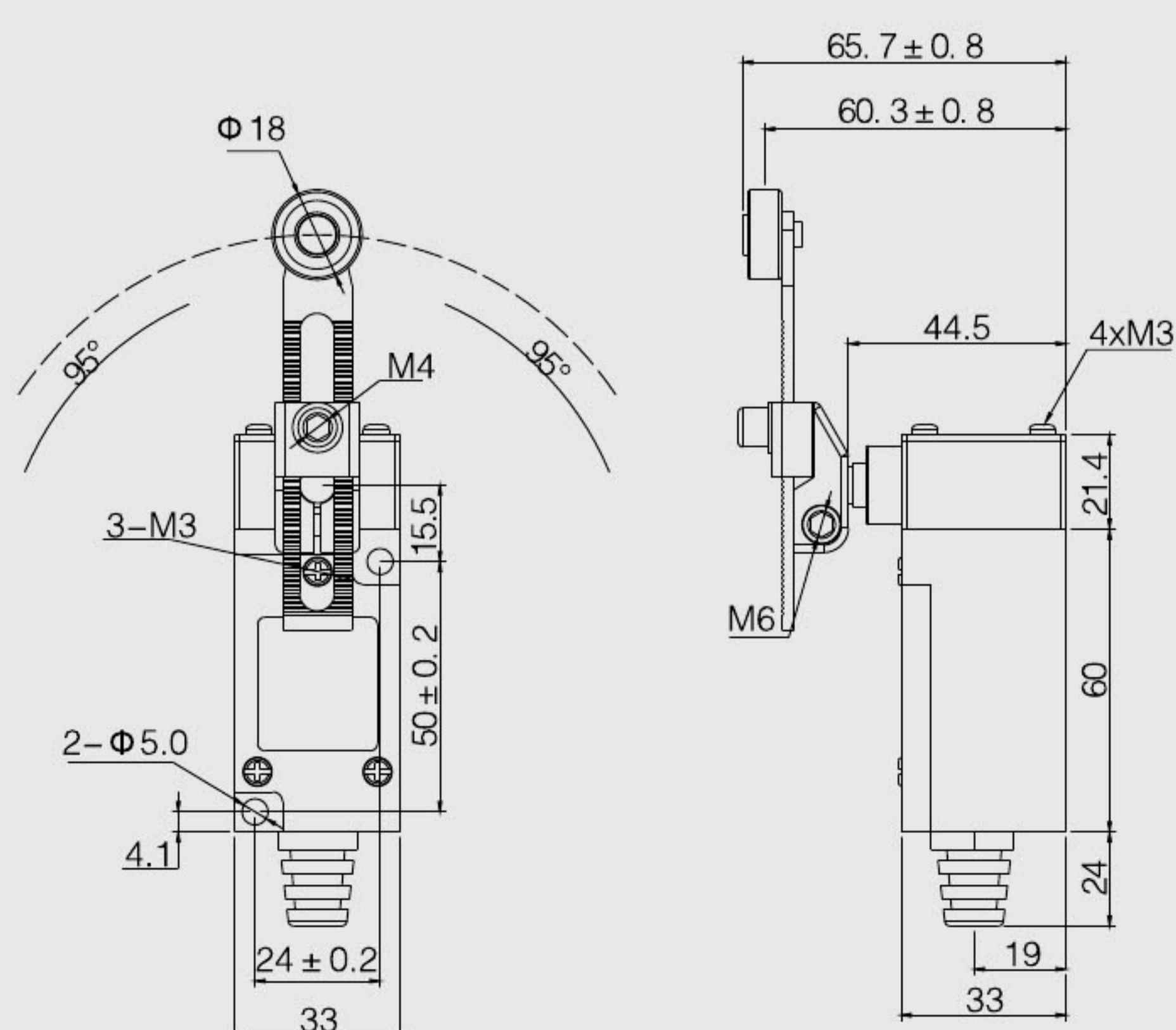

动作力	OF max.	500g(4.9N)
回复力	RF min.	80g(0.78N)
预行程	PT max.	30°
超行程	OT min.	70°
差行程	MD max.	15°
总行程	TT	90

□外形尺寸/动作特性 Dimensions/Operating Characteristics

• 可调圆棒摆杆型
XHL-5050

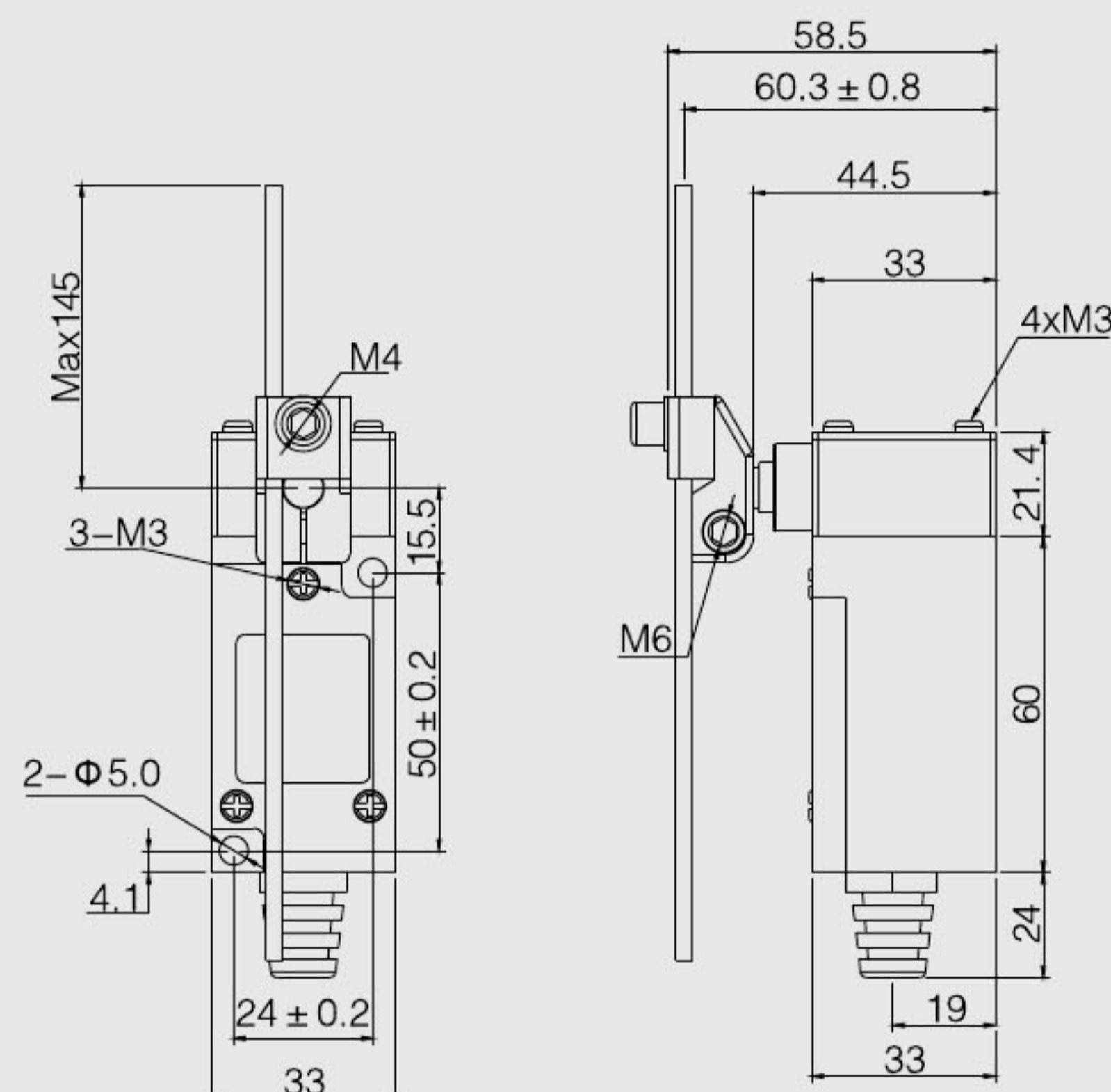

动作力	OF max.	500g(4.9N)
回复力	RF min.	80g(0.78N)
预行程	PT max.	30°
超行程	OT min.	70°
差行程	MD max.	15°
总行程	TT	90

• 按钮型
XHL-5100

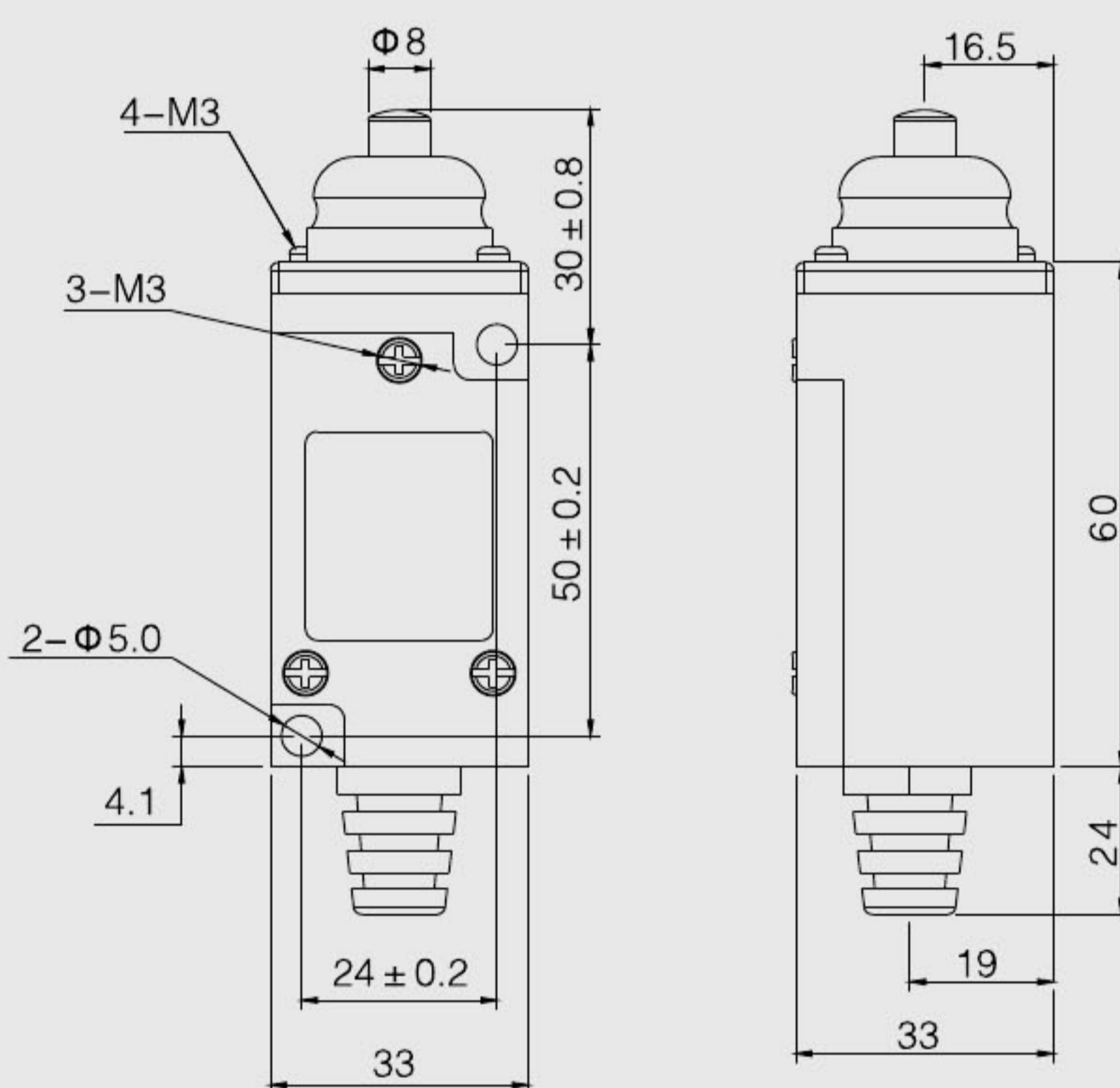

动作力	OF max.	500g(4.9N)
回复力	RF min.	80g(0.78N)
预行程	PT max.	30°
超行程	OT min.	70°
差行程	MD max.	15°
总行程	TT	90°

• 滚轮按钮型
XHL-5200

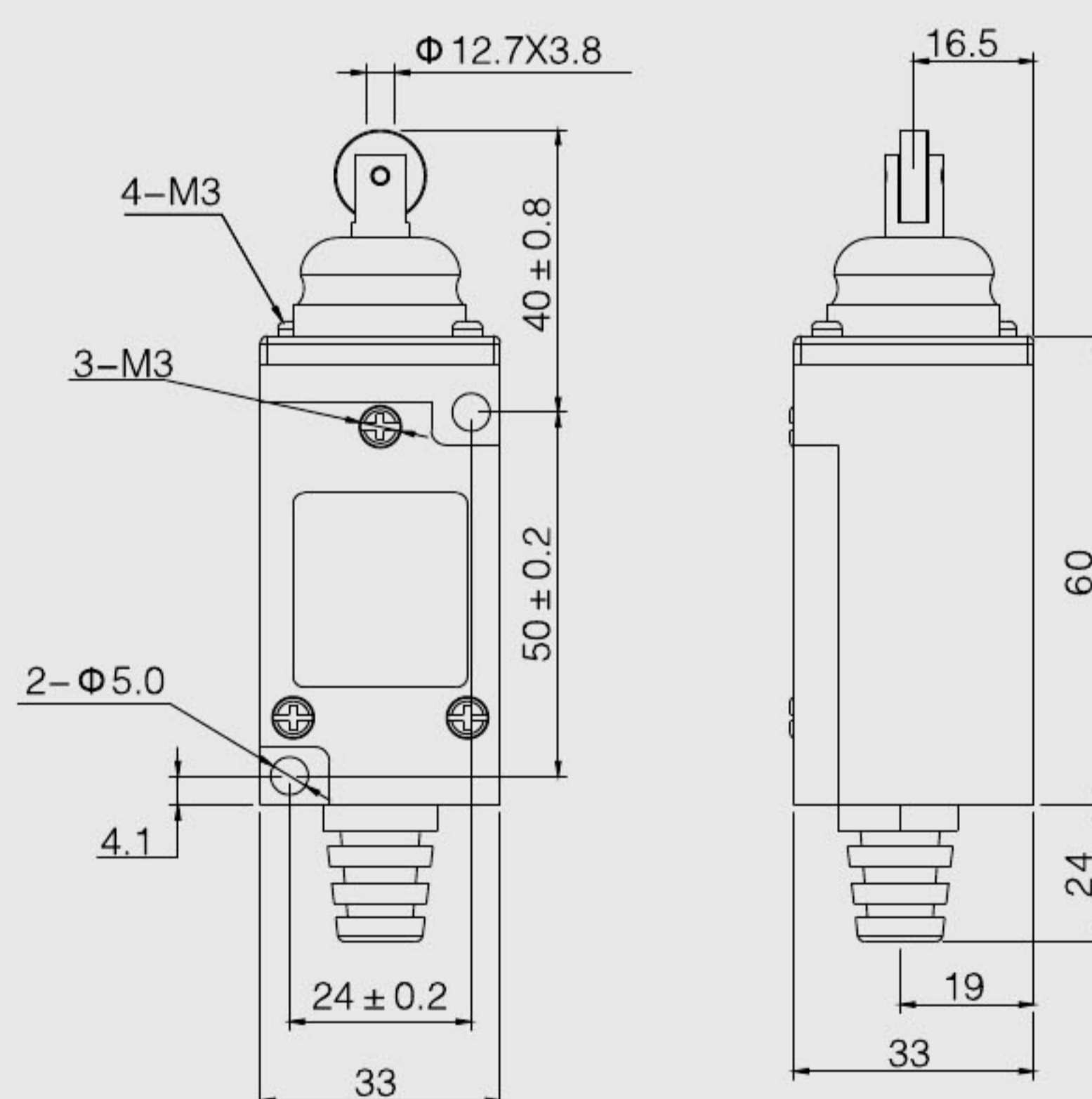

动作力	OF max.	700g(6.86N)
回复力	RF min.	180g(1.76N)
预行程	PT max.	2.5mm
超行程	OT min.	3mm
差行程	MD max.	1.2mm
总行程	TT	5.8mm

• 万向式弹簧摇杆型
XHL-5300

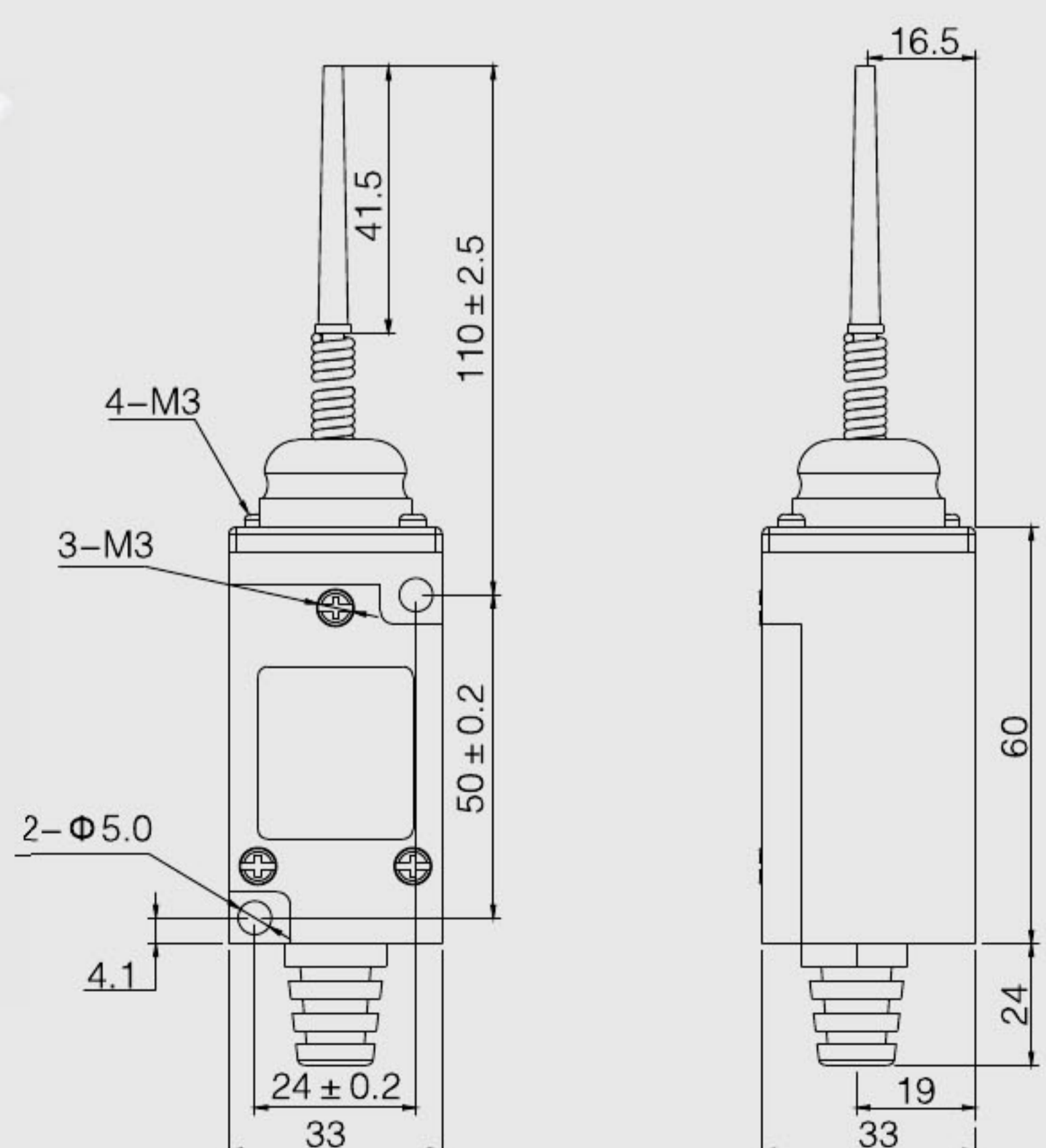

动作力	OF max.	100g(0.98N)
回复力	RF min.	30g(0.29N)
预行程	PT max.	28mm
超行程	OT min.	20mm
差行程	MD max.	10mm
总行程	TT	48mm